

Basic Pneumatics

Table of Contents

Lesson One	Pneumatic Principles.....	3
Lesson Two	Reciprocating Compressors.....	19
Lesson Three	Rotary Compressors.....	35
Lesson Four	Primary Air Treatment.....	51
Lesson Five	Secondary Air Treatment.....	67
Lesson Six	Piping, Hoses, and Fittings.....	83
Lesson Seven	Directional-Control Valves.....	99
Lesson Eight	Pressure-Control Valves.....	115
Lesson Nine	Pneumatic Cylinders.....	131
Lesson Ten	Pneumatic Motors and Rotary Actuators.....	147

© Copyright 1987, 2001, 2003 by TPC Training Systems, a division of Telemedia, Inc.

All rights reserved, including those of translation.

Printed and videotaped courseware are subject to the copyright laws of the United States. You are not authorized to make any copies of this material. If you do, then you are subject to the penalties provided under the copyright law, which include statutory damages up to \$50,000 for each infringement of copyrighted material, and also recovery of reasonable attorneys' fees. Further, you could be subject to criminal prosecution pursuant to 18 U.S.C. § 2319.

BASIC PNEUMATICS

Lesson One

***Pneumatic
Principles***

PREVIEW
COPY

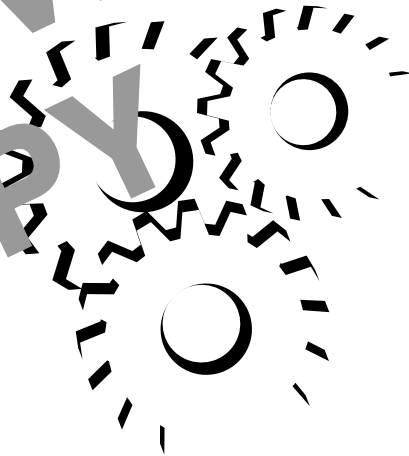

TPC Training Systems

30901

Lesson**1*****Pneumatic Principles*****TOPICS**

Fluid Power Systems
 Pneumatic Systems
 Force, Weight, and Mass
 Pressure
 Work and Energy
 Diffusion and Dispersion
 Separation of Gases and Liquids
 Compressibility

Laws of Pneumatics
 Transmission of Pneumatic Fluid Power
 Pneumatic Leverage
 Air Properties
 Air Flow in Pipes
 Viscosity of Air
 Bernoulli's Law
 Components of Pneumatic Power Systems

OBJECTIVES

After studying this lesson, you should be able to...

- Explain how force is transmitted in a pneumatic system.
- Calculate force and work.
- List two factors that affect the results of pressure calculations.
- Explain pneumatic leverage.
- Briefly explain the physical laws affecting the behavior of a confined gas.

KEY TECHNICAL TERMS

Pneumatic system 1.01 a system that uses a gas to transmit force
Force 1.04 a push or pull exerted on an object to change its position or movement
Density 1.08 the weight of an object for a specific volume or unit of measure

Pressure 1.10 the amount of force (lb) exerted on an object or substance, divided by the area (in²) over which the force is exerted
Streamline (laminar) flow 1.38 movement of air layers in nearly parallel lines
Dynamic viscosity 1.42 viscosity of air molecules; air's resistance to flow

Specific pneumatic components vary in construction and appearance, and are used for many different applications. However, the basic working principles that determine the operation and action of a pneumatic system remain the same. This lesson outlines some of these operating principles.

A familiarity with the principles behind the operation of pneumatic equipment should help you to know just how much work a device can do for you. Understanding the principles of a pneumatic system can also help you solve some of the operating problems that arise. That same understanding should enable you to take corrective action before a failure or breakdown occurs.

Fluid Power Systems

1.01 All industrial plants use a fluid power system of one type or another. Work is performed by a fluid under pressure in the system. A fluid power system may function as part of a process, such as heating or cooling, or it may be used as a secondary service system, such as compressed air. A fluid can be either a liquid, such as oil or water, or a gas. A fluid power system that uses a liquid in order to transmit force is called a *hydraulic system*, and was discussed in Course 307. A system that uses a gas for transmitting force is called a *pneumatic system*. The word “pneumatic” is derived from the Greek word for an unseen gas. Originally pneumatic referred only to the flow of air. Now it includes the flow of any gas in a system under pressure.

Pneumatic Systems

1.02 Some applications of pneumatic systems include operating pneumatic tools, linear motion devices, door openers, and rotary motion devices. Pneumatic hoisting equipment may be found in heavy fabricating environments, and pneumatic conveyors are used in the processing of raw materials. Pneumatic systems are also used to control flow valves in chemical process equipment and in large air-conditioning systems.

1.03 The pneumatic system in an industrial plant usually handles compressed air. Compressed air is used for operating portable air tools, such as drills, wrenches, and chipping tools; for vises, chucks, and other clamping devices; for movable locating stops; for operating hot die casting and plastic molding machines; and also for supplying air used in manufacturing processes. Although the pieces of pneumatic equipment just described are different from each other, they all convert compressed air into work. Before discussing pneumatic

systems and their operation, this lesson will review some laws of force and motion, their relation to pneumatic principles, and how they are used.

Force, Weight, and Mass

1.04 A *force* is a push or a pull exerted on an object to change its position or movement. This includes starting, stopping, and changing its speed or direction of movement. In a pneumatic system, force must be present at all times for the system to function. This force is exerted by compressed air.

1.05 As shown in Fig. 1-1, a compressor takes air at atmospheric pressure, compresses it, and stores it in a tank. The air in the tank flows into the air lines that run from the tank to the equipment. Pressure is developed by the resistance of the system components and the compressor discharge valves. When the equipment is in use, the force of the high-pressure air must be sufficient to overcome the resistance to airflow offered by the piping and to drive the equipment that does the work of the system. The greater the system’s work load, the more force is needed.

Fig. 1-1. Force in a pneumatic system

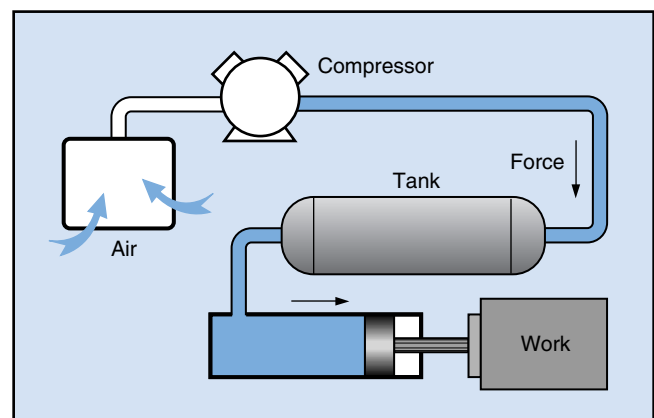
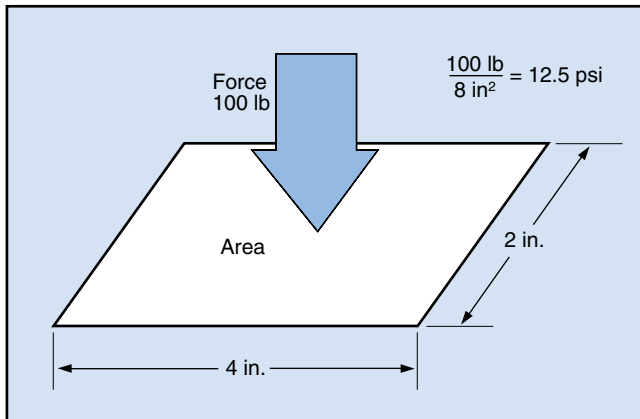

Fig. 1-2. Determining pressure



1.06 An object or substance has *weight* as a result of the gravitational force or pull on the object. In a pneumatic system, the compressor, tank, lines, all of the components, and even the air in the system have weight. This is true whether the air is held in the tank or is moving through the system.

1.07 All objects and substances have mass. *Mass* represents the amount of matter in an object, and its *inertia*, or resistance to movement. An object's mass determines its weight on earth or in any other gravitational field. An object's inertia determines how much force is needed to lift or move the object or to change its speed or direction of movement.

1.08 The *density* of an object is its mass for a specific volume or unit of measure. The density of a cubic foot of "dry" air at atmospheric pressure and a temperature of 60°F is 0.076 lb. This is more commonly expressed as 0.076 lb/ft³. The density of "wet" air at atmospheric pressure, with 100% relative humidity, and a temperature of 60°F is 0.075 lb/ft³. Humid air is less dense than dry air because the water vapor will not allow the air to compress as much. As a result, humid air weighs less. Air having a density of 0.076 lb/ft³ requires approximately 13.2 ft³ of air to equal 1 lb.

1.09 As you know, air is very light compared to water or hydraulic fluid. Its relatively low density makes it suitable for long-distance and high-speed control applications. Also, because of its low weight and inertia, it will not cause pneumatic shocks as hydraulic fluid does when a valve is closed quickly.

Pressure

1.10 *Pressure* is the amount of force (in pounds) exerted on an object or a substance, divided by the area (in square inches) over which this force is exerted. Although pressures are measured and specified in different ways, the use of pounds per square inch (psi) is the most common. If a 100 lb force is applied to an area of 8 in² (Fig. 1-2), the resulting pressure is 12.5 psi. If the pressure (in psi) on a certain area (square inches) is known, the total force (in pounds) exerted by the pressure is equal to the pressure multiplied by the area.

1.11 Pneumatic systems deal with three kinds of pressure—atmospheric, below atmospheric, and pneumatic system pressure. Atmospheric pressure at sea level equals 14.7 psi. Pressure is lower above sea level and higher below sea level. A difference in pressure also allows air to pass through a compressor's intake filter and into the cylinder. This occurs when the compressor is on the intake stroke, and pressure in the cylinder is below atmospheric.

1.12 The absence of air (complete or partial), indicating below atmospheric pressure, is often referred to as a *vacuum* or *partial vacuum*. For some applications, it may also be called a *negative* or *suction pressure*. Vacuum is measured with the aid of a column of mercury or with special gauges. When all the air above the column is evacuated, atmospheric pressure is exerted on the pool of mercury below the tube. This pressure raises the column to a height of approximately 30 in. In most applications a vacuum is measured in inches of mercury instead of psi. However, pneumatic pressure acting *within* a pneumatic system is measured in psi.

1.13 Most pressure gauges in a pneumatic system measure only pressure that is higher than the atmospheric pressure surrounding them. When disconnected, a pressure gauge reads zero pounds per square inch, *gauge* (0 psig). A reading of 250 on a pneumatic pressure gauge tells you that the air pressure is 250 psi above atmospheric. Add atmospheric pressure to this gauge pressure, and the total pressure is 264.7 lb/in², *absolute* (psia). Although absolute pressure readings are important in some pneumatic calculations, the distinction between psig and psia is usually not very important in the average pneumatic system. As a result, gauge pressure readings are usually expressed in psi.

Work and Energy

1.14 *Work* takes place when a force (in pounds or newtons) moves through a distance (in inches, feet, or meters). The amount of work done is expressed in the English system of measurement in foot-pounds or inch-pounds, as shown in the following equation:

$$\begin{aligned} \text{Work} &= \text{force (in pounds)} \times \text{distance (in feet or inches, parallel to the direction of force)} \\ &= \text{foot-pounds or inch-pounds.} \end{aligned}$$

1.15 In a pneumatic system, the force in pounds is exerted by air pressure acting on the area of a moving piston in a cylinder, as shown in Fig. 1-3. As the piston moves, the pneumatic force acts through the length of the stroke. You can determine the work done by the piston by using the following equations:

$$\begin{aligned} \text{Force (F)} &= \text{pressure} \times \text{piston area} \\ &= \frac{\text{lb}}{\text{in}^2} \times \text{in}^2 \\ &= \text{lb.} \end{aligned}$$

$$\begin{aligned} \text{Work (W)} &= \text{force} \times \text{piston travel} \\ &= \text{lb} \times \text{in.} \\ &= \text{in-lb.} \end{aligned}$$

To convert to foot-pounds, divide by 12:

$$\frac{\text{in-lb}}{12} = \text{ft-lb.}$$

1.16 *Power* is defined as the amount of work (foot-pounds) done in a given length of time (seconds or minutes), or foot-pounds per minute. The following equation will give you the amount of power:

$$\begin{aligned} \text{Power (P)} &= \frac{\text{work}}{\text{time}} \\ &= \frac{\text{ft-lb}}{\text{seconds (or minutes)}} \end{aligned}$$

Since the work in the above equation is given in foot-pounds, if you wish to know the answer in inch-pounds, you should multiply by 12.

1.17 For the amount of power calculated to be meaningful, it must be compared with a unit of measurement. The common unit of power measurement is horsepower, calculated as follows:

$$1 \text{ hp} = \frac{33,000 \text{ ft-lb}}{1 \text{ minute}}$$

or, alternatively:

$$1 \text{ hp} = \frac{550 \text{ ft-lb}}{1 \text{ second.}}$$

Fig. 1-3. Comparison of pneumatic and mechanical work

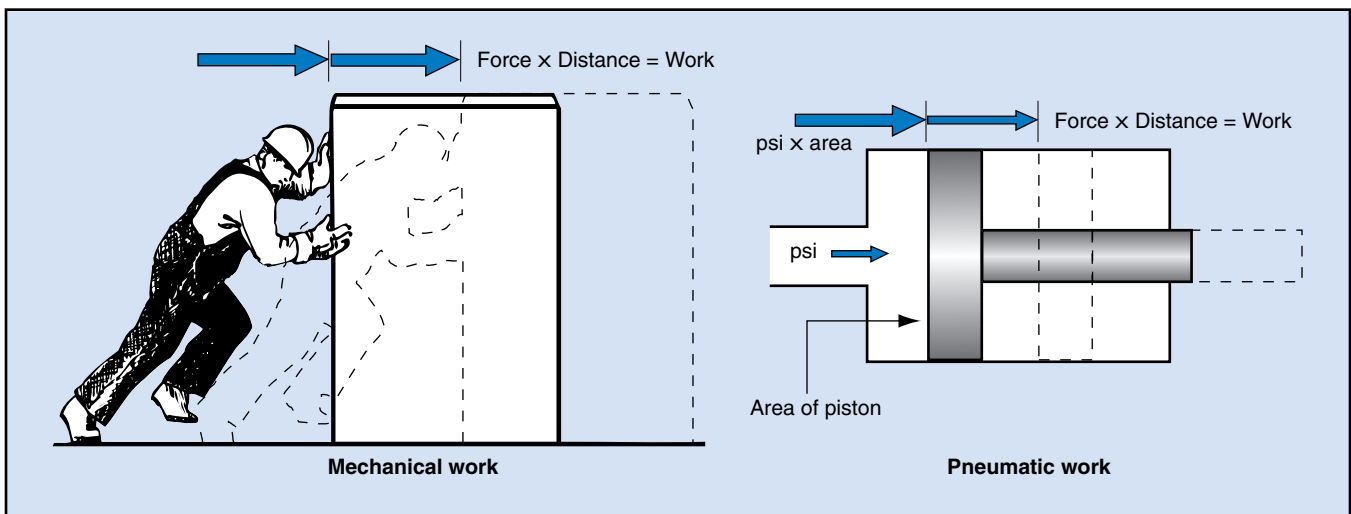

1.18 To use power and do work, energy must be expended. The Law of Conservation of Energy states that: “Energy cannot be created or destroyed, it can only be transformed.” Therefore, we use one kind of energy to get other kinds of energy. Some of this energy does useful work. Some of it only overcomes friction. The energy that overcomes friction is not lost, but is changed into heat energy.

1.19 The forms of energy used in pneumatic systems include the following:

- *electrical energy*, which operates the compressor motor
- *mechanical energy*, which is produced by the compressor
- *heat energy*, produced by friction in the compressor motor, the compressor, the moving air, and the moving piston.

In addition, a pneumatic system possesses two types of energy, which will be discussed later in this lesson:

- *kinetic energy*, produced when the compressed air is lifting or moving an object
- *potential energy*, which the lifted or moved object now has.

Diffusion and Dispersion

1.20 *Diffusion* can be described as the rapid intermingling of the molecules of one gas with another. This should not be confused with evaporation, which is the changing of a liquid to a vapor. To prevent com-

pressed gases from rapidly diffusing into the surrounding air, they must be stored in closed containers.

1.21 *Dispersion* can be described as the temporary mixing of liquid particles with a gas. When air is compressed, compressor lubricating oil is picked up by the moving air in the compressor and dispersed in fine particles that remain suspended in the air for a time. If enough heat is generated in the compressor, some of the oil evaporates and is diffused in the air. Most of the large particles of oil dispersed in compressed air drop out when the air goes around sharp corners, or blows against a flat plate or through a screen, or when it comes to rest in a tank. Finely dispersed oil particles and oil or water vapor that have been diffused into the air are more difficult to remove.

Separation of Gases and Liquids

1.22 Although diffusion and dispersion should be kept to a minimum, liquids (especially water) constantly evaporate into the surrounding gases. Because liquids are heavier than gases, they do not mix readily. Therefore, when air and suspended water or oil are put in the same tank, or flow through the air lines, the water or oil will settle out and flow to the lowest places. That is why water usually collects at the bottom of a vertical air line, where it should exit through a drain valve.

The Programmed Exercises on the next page will tell you how well you understand the material you have just read. Before starting the exercises, remove the Reveal Key from the back of the book. Read the instructions printed on the Reveal Key. Follow these instructions as you work through the Programmed Exercises.

<p>1-1. The "fluid" in a fluid power system can be either a(n) _____ or a(n) _____.</p>	<p>1-1. GAS, LIQUID Ref: 1.01</p>
<p>1-2. In a pneumatic system, the force that does the work is usually supplied in the form of _____.</p>	<p>1-2. COMPRESSED AIR Ref: 1.04</p>
<p>1-3. The pressure in a compressed air system is caused by the resistance of the components and the compressor _____ valves.</p>	<p>1-3. DISCHARGE Ref: 1.05</p>
<p>1-4. The amount of force required to start an object in motion or change its motion is determined by the object's _____.</p>	<p>1-4. INERTIA Ref: 1.07</p>
<p>1-5. Gauge pressure (psig) indicates air pressure _____ atmospheric pressure.</p>	<p>1-5. ABOVE Ref: 1.13</p>
<p>1-6. The amount of work done by a cylinder having a 10 in² piston area and a 12 in. stroke when operated at 50 psi equals _____ ft-lb.</p>	<p>1-6. 500 Ref: 1.15, Fig. 1-3</p>
<p>1-7. Power is calculated by dividing the amount of work done by the _____.</p>	<p>1-7. TIME IT TOOK TO DO THE WORK Ref: 1.16</p>
<p>1-8. The mechanical energy in a compressed air system is produced by the _____.</p>	<p>1-8. COMPRESSOR Ref: 1.19</p>

Compressibility

1.23 Unlike liquids, which are virtually incompressible, air is readily compressible and can be stored in large quantities in relatively small containers. The more the air is compressed, the higher its pressure becomes. The higher the pressure in a container, the stronger the container must be.

Laws of Pneumatics

1.24 One of the more well-known physical laws that govern the behavior of pneumatic systems is Pascal's Law. *Pascal's Law* states that when a gas is confined under pressure in a closed container, the pressure is transmitted equally in all directions by the gas. This is shown in Fig. 1-4. If the container is flexible, it will assume a spherical (balloon) shape. Most compressed-gas tanks are long cylinders with spherical ends to contain the pressure more effectively. With this design, a pressure vessel can be made from thinner sheets of steel without sacrificing safety.

1.25 The basic relationship between the pressure of a gas and its volume is given in *Boyle's Law*, which states: "The absolute pressure of a confined quantity of gas varies inversely with its volume, if its temperature does not change." This means that if 10 ft³ of air at 14.7 psia is compressed to 1 ft³, air pressure will rise to 147.0 psia, as long as air temperature remains the same. Figure 1-5 shows this relationship, which can be calculated as follows:

$$P_1 \times V_1 = P_2 \times V_2$$

where P_1 and P_2 are the pressures before and after compression, and V_1 and V_2 are the volumes before and after compression. This equation can also be written as:

Fig. 1-4. Action of confined air pressure

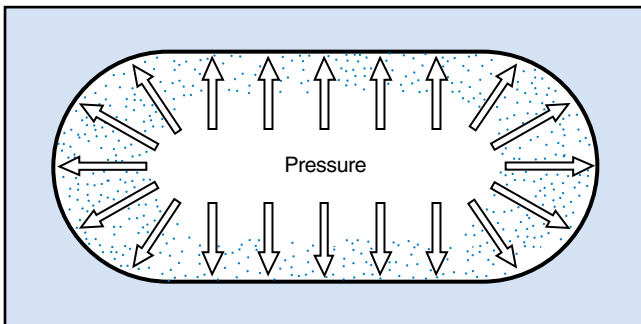

$$\frac{P_2}{P_1} = \frac{V_1}{V_2} \text{ or } \frac{P_1}{P_2} = \frac{V_2}{V_1}$$

To allow for the effects of atmospheric pressure, always remember to convert from gauge pressure *before* solving the problem, then convert back to gauge pressure *after* solving it:

$$\text{psia} = \text{psig} + 14.7 \text{ psi}$$

and

$$\text{psig} = \text{psia} - 14.7 \text{ psi.}$$

1.26 Usually a compression problem like the one above is stated as follows: What is the gauge pressure of 10 ft³ of air at 25.3 psig when compressed to 5 ft³? The problem would be solved like this:

$$25.3 \text{ psig} + 14.7 \text{ psi} = 40 \text{ psia}$$

$$P_2 = P_1 \times \frac{V_1}{V_2} = 40 \times \frac{10}{5} = 80 \text{ psia}$$

$$\text{psig} = \text{psia} - 14.7 \text{ psi}$$

$$= (80 \text{ psia}) - (14.7 \text{ psi}) = 65.3 \text{ psig.}$$

Remember that the pressures should always be calculated on the basis of absolute pressures instead of gauge pressures. Otherwise you would get a much different—and incorrect—answer.

1.27 Another physical law dealing with heat is *Charles's Law*. It states: "If the volume of a confined quantity of gas remains the same, the change in the pressure of the gas varies directly with a change in the absolute temperature (T) of the gas." This is calculated by using the following equation:

$$P_2 = P_1 \times \frac{T_2}{T_1}$$

1.28 Charles's Law also states: "If the pressure of a confined quantity of gas remains the same, the change in the volume (V) of the gas varies directly with a change in the temperature of the gas," as given in the equation:

$$V_2 = V_1 \times \frac{T_2}{T_1}$$

Fig. 1-5. Boyle's Law

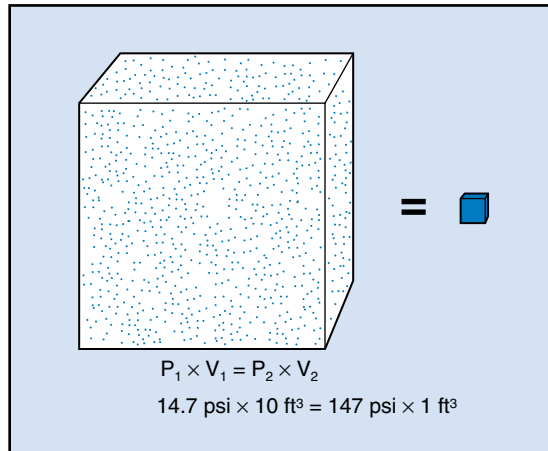

1.29 In both of the above equations, the temperature is stated as absolute temperature. Absolute temperature is used when applying Charles's Law in order to avoid the confusion that might occur with degrees Fahrenheit or Celsius. *Absolute temperature* begins at absolute zero, which is found at -460°F , or 0°R (zero degrees Rankine). Rankine was the scientist who discovered absolute zero. On this basis, 0°F equals 460°R and 60°F equals 520°R ($460^\circ\text{R} + 60^\circ\text{F}$).

1.30 Because air cannot be compressed without its temperature changing, Boyle's and Charles's Laws do not operate separately in a real pneumatic system. They operate together, according to the Ideal Gas Law expressed by the equation:

$$\frac{P_1 \times V_1}{T_1} = \frac{P_2 \times V_2}{T_2}$$

Note that this equation uses absolute pressure (psia) and absolute temperatures ($^\circ\text{R}$) in its calculations. The equation also shows that the pressure, volume, and temperature of the second state of a gas are equal to the pressure, volume, and temperature of the first state. In actual practice, however, other factors such as humidity, heat of friction, and efficiency losses all affect the gas. The Ideal Gas Law is still used as a design equation.

Transmission of Pneumatic Fluid Power

1.31 Using compressed air to do work requires the application of all the points covered so far. As shown in Fig. 1-6A, if a force of 10 lb is applied to piston 1, it is transmitted through the air in the cylinder to pis-

Fig. 1-6. Transmission of force

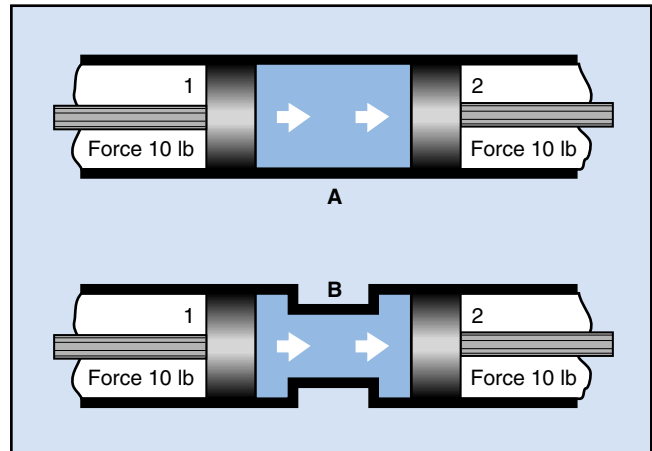

ton 2. Pascal's Law states that pressure developed in confined gas is equal at every point touched by the gas. Therefore the internal air pressure developed by piston 1 pushes on piston 2. If each piston's area is the same, the force developed on piston 2 is the same as the force applied to piston 1 (if frictional losses are not considered).

1.32 The single cylinder in Fig. 1-6A has been replaced by two individual cylinders in Fig. 1-6B. Both cylinders have the same diameter and are connected with a suitable air line. The conditions present in Fig. 1-6A have not changed, because the pneumatic system has not changed. The force applied to piston 1 is transmitted through the fluid (gas) to piston 2.

Pneumatic Leverage

1.33 A similar arrangement of two pistons connected by an air line is shown in Fig. 1-7 on the following page. However, the pistons are placed in a vertical position and are of different sizes. If a force of 100 lb is applied to piston 1, the force is distributed over the 10 in² area of the piston. A pneumatic pressure of 10 psi ($100 \text{ lb} \div 10 \text{ in}^2$) builds up under piston 1 and throughout the system, including the 50 in² area under piston 2. The 10 psi pneumatic pressure exerts a maximum total force of 500 lb on piston 2 ($10 \text{ psi} \times 50 \text{ in}^2$). This increase in force is called *pneumatic leverage* or *force multiplication* and occurs in all similar applications.

1.34 If the 500 lb force is applied against piston 2, the output force on piston 1 is only 100 lb. The calculations remain the same:

Fig. 1-7. Unequal piston areas

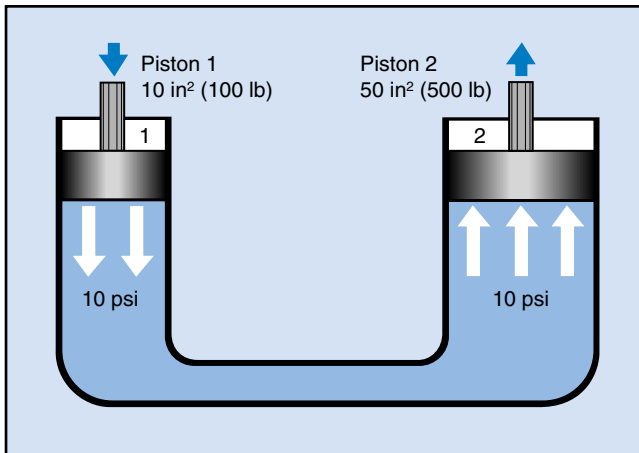

$$500 \text{ lb} \div 50 \text{ in}^2 = 10 \text{ psi}$$

$$10 \text{ psi} \times 10 \text{ in}^2 = 100 \text{ lb.}$$

In this instance, the pneumatic leverage (or force) is decreased instead of increased.

1.35 There is another principle of leverage that also must be remembered. That is, for every force increase, there is a corresponding movement decrease. If piston 1 in Fig. 1-7 moves 5 in., it displaces 50 in³ of air (5 in. \times 10 in² = 50 in³) under the cylinder. The 50 in³ of air is transmitted through the system to piston 2. The 50 in³ of air acts on the 50-in² area of piston 2, causing it to move 1 in. (50 in³ \div 50 in² = 1 in.).

1.36 The example in Fig. 1-7 shows that for a 5 to 1 (5:1) pressure increase, there is a directly opposite (1:5) travel decrease. The same proportion exists for any leverage ratio. If the original force is applied to the large piston instead of to the small piston, the force exerted on the small piston decreases, but its amount of travel increases.

Air Properties

1.37 Up to now, we have discussed how air is lighter (less dense) than a liquid and will diffuse into another gas; that water vapor and oil vapor will diffuse into air; and that oil particles can be suspended in air. We have also discussed the compressibility of air and the pressure-volume-temperature relationships of a confined quantity of air. To understand

Fig. 1-8. Streamline flow

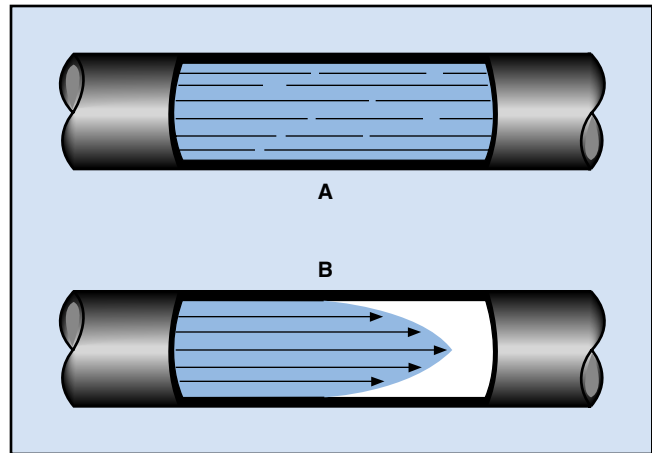

how well and how quickly air will transmit force and movement, you have to know something about air and how it flows.

Air Flow in Pipes

1.38 *Streamline* or *laminar flow* is the ideal type of airflow in a pneumatic system because the air layers move in nearly parallel lines (Fig. 1-8A). Like all fluids, the layer of air next to the surface of the pipe moves the slowest because of the friction between the fluid and the pipe. The layer of moving fluid (air) next to the outermost layer moves a little faster, and so on, until the fluid layers nearest the center of the flow passage move the fastest. Figure 1-8B shows the greatest velocity of flow near the center of the pipe.

1.39 *Turbulent flow* conditions usually occur because the flow passage is too small for the desired flow velocity of the air. The density and viscosity of the air also affect turbulent flow, but not as much as the flow passage and the flow velocity. Rough or irregularly formed air passages, sudden enlargement or reduction in the diameter of the flow passages, and sudden changes in the direction of flow should all be avoided. When air must pass through a passage of reduced size, the restriction should be smooth and gradual.

1.40 Turbulent flow heats the air, wastes power by requiring higher air pressure, and can damage the flow passages and ports in the pneumatic equipment.

Viscosity of Air

1.41 The *viscosity* of air is its resistance to flow, because it is a measure of the air's internal friction. In more specific terms, it is a measure of the resistance to one layer of moving air in a flow passage sliding over another (laminar flow).

1.42 The viscosity of air is referred to as *dynamic viscosity* or *absolute viscosity*. This is a measure of the activity of air molecules with increases in temperature. As the temperature increases, the molecules bump into each other much more frequently while they are moving. This means they will have greater resistance to flow and also a higher dynamic viscosity.

Bernoulli's Law

1.43 Compressed air in a pneumatic system possesses two types of energy, kinetic and potential. *Kinetic energy* is present when the air is moving, and *potential energy* is a result of the air pressure. *Bernoulli's Law* states that, in an ideal system, if air velocity increases, the kinetic energy of the air also increases, while the *total energy* (potential energy + kinetic energy) of the air remains constant. If the kinetic energy increases and the total energy remains the same, the potential energy of the air moving in a reduced flow passage is reduced. If the potential energy is reduced, the pressure of the air is also reduced, as shown in Fig. 1-9.

Components of Pneumatic Power System

1.44 Many varieties of pneumatic systems are used in industrial plants. Briefly described, a pneumatic system is a piping circuit in which air under controlled pressure is used to transmit force to do work. It is often called an *open system* because it takes in air at atmospheric pressure, and exhausts air to the atmosphere when work is done.

1.45 A basic pneumatic system (Fig. 1-10) is usually modified by the addition of other components that enable the system to perform a greater range of work and to function more reliably. The following components, shown in Fig. 1-11 on the following page, make up the modified basic pneumatic power system:

- an intake filter and silencer (1) to clean the air being used by the system
- a compressor (2) to compress room air and deliver it under pressure
- an aftercooler (3) for the compressed air
- a separator (4) to remove condensed water and oil from the air
- a pressure switch (5) to start and stop the compressor as required
- a relief valve (6) that functions if the pressure switch fails
- a tank (7) to store the compressed air
- a filter, pressure regulator, and lubricator assembly (8) to prepare the air for use

Fig. 1-9. Illustration of Bernoulli's Law

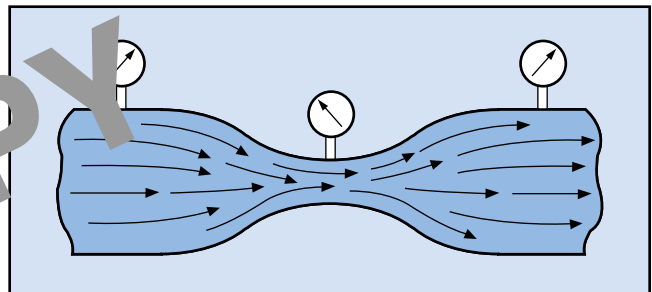

Fig. 1-10. A basic pneumatic system

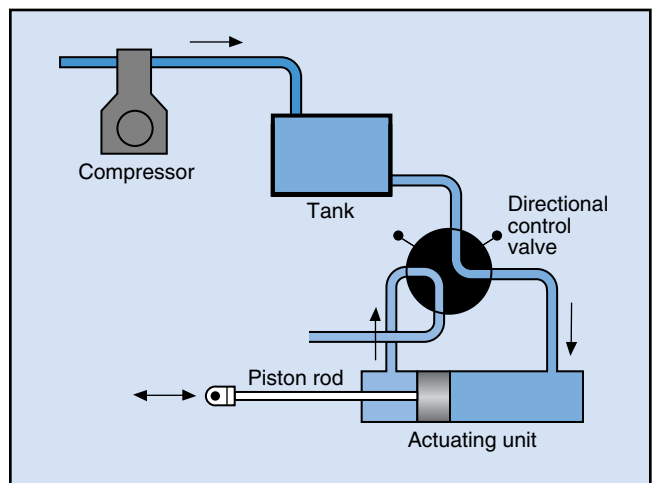
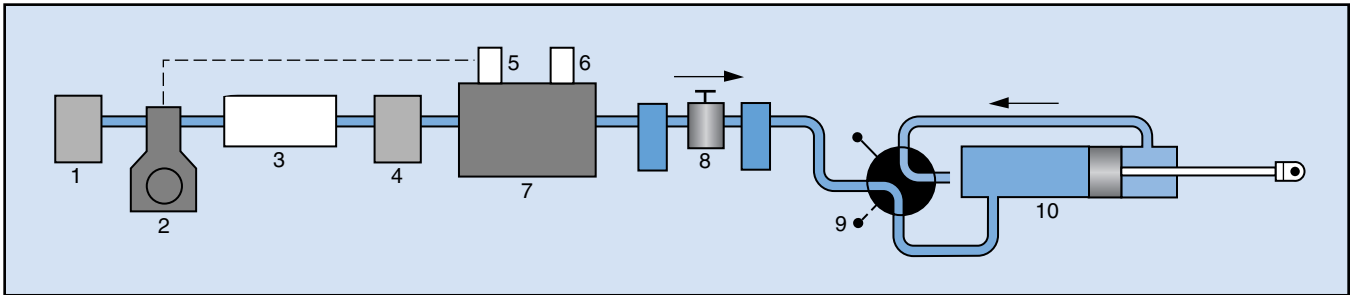

Fig. 1-11. A modified basic pneumatic system

- a directional control valve setup, with safety features (9)
- an actuating unit (10) at each work station where necessary. These can be cylinders, motors, or air-operated pumps.
- piping to transmit the compressed air through the system. The piping also includes drip legs and dirt traps with valves for removing contaminants.

The following lessons will cover these components in greater detail.

**PREVIEW
COPY**

16 Programmed Exercises

<p>1-9. The equation $P_1 \times V_1 = P_2 \times V_2$ means that even though the pressure and volume of a gas change, their total product is always _____.</p>	<p>1-9. EQUAL or SAME Ref: 1.25, Fig. 1-5</p>
<p>1-10. Charles's Law says that if the volume of a gas is unchanged, its pressure will vary with its _____.</p>	<p>1-10. TEMPERATURE Ref: 1.27</p>
<p>1-11. If a 100 lb force is applied to one of two equal-sized pistons, the second piston will produce _____ lb of force.</p>	<p>1-11. 100 Ref: 1.31, Fig. 1-6</p>
<p>1-12. What would the output force be if a 50 lb force is applied to a piston having an area of 10 in² and transferred to a piston having an area of 75 in²?</p>	<p>1-12. 375 LB OF FORCE Ref: 1.33, Fig. 1-7</p>
<p>1-13. For every increase in pneumatic force in a pneumatic system, there is a(n) _____ in travel.</p>	<p>1-13. DECREASE REF: 1.35, FIG. 1-7</p>
<p>1-14. The ideal airflow in a pneumatic system is called _____ airflow.</p>	<p>1-14. STREAMLINE Ref: 1.38, FIG. 1-8</p>
<p>1-15. The viscosity of air is a measure of the air's _____.</p>	<p>1-15. INTERNAL FRICTION Ref: 1.41</p>
<p>1-16. In an ideal compressed air system, the total energy (kinetic and potential) always remains _____.</p>	<p>1-16. CONSTANT Ref: 1.43, Fig. 1-9</p>

Answer the following questions by marking an "X" in the box next to the best answer.

- 1-1. In a pneumatic system, the compressed air provides the force to
- a. control the dew point
 - b. cool the compressor
 - c. lubricate the tools
 - d. perform work
- 1-2. The inertia of an object is its
- a. density
 - b. resistance to movement
 - c. specific gravity
 - d. velocity
- 1-3. The abbreviation "psig" means
- a. pound signal, indicating gauge
 - b. pounds per square inch, gauge
 - c. pressure per square inch, gauge
 - d. pressure signal, indicating gauge
- 1-4. The amount of work done by a pneumatic cylinder is equal to the force times the
- a. length of time
 - b. piston area
 - c. piston travel
 - d. pressure
- 1-5. What type of energy is produced by an air compressor?
- a. Dynamic
 - b. Electrical
 - c. Kinetic
 - d. Mechanical
- 1-6. Using the equation $P_1 \times V_1 = P_2 \times V_2$, find P_2 if $P_1 = 100$ (psig), $V_1 = 100$, $V_2 = 10$. (Remember to do all calculations in psia)
- a. 1000 (psig)
 - b. 1132 (psig)
 - c. 11,470 (psig)
 - d. 14,700 (psig)
- 1-7. What happens when heat is applied to gas contained in a cylinder?
- a. The cylinder expands
 - b. The mass decreases
 - c. The pressure increases
 - d. The volume increases
- 1-8. The force that permits a small amount of pressure to move a larger object is called
- a. pneumatic leverage
 - b. pneumatic power
 - c. power differential
 - d. power ratio
- 1-9. If the small piston in a pneumatic system having 2.5-to-1 leverage increase travels 5 in., how far will the large piston travel?
- a. 2 in.
 - b. 2.5 in.
 - c. 5 in.
 - d. 12.5 in.
- 1-10. Bernoulli's principle states that the total energy (potential + kinetic) of a gas in a pneumatic system always
- a. decreases
 - b. fluctuates
 - c. increases
 - d. remains constant

SUMMARY

Pneumatic systems use a gas under pressure (such as compressed air) to transmit force. A force is a push or pull exerted on an object to change its position or movement. The more work the system does, the more force must be supplied.

Force in a pneumatic system is equal to the pressure (psi) times the piston area (square inches). The work done by the piston is equal to the product of the pounds of force times the distance the piston travels. Power is the amount of work (foot-pounds) divided by the time it took to do it. Power is generally measured in horsepower.

The behavior of a gas in a pneumatic system is described in several well-known physical laws. They state that a pressurized gas confined in a closed container has the following characteristics: 1.) It transmits pressure equally in all directions. 2.) At a constant temperature, its pressure varies inversely with its volume. 3.) At a constant volume, its pressure varies directly with its temperature. 4.) At a constant pressure, its volume varies directly with its temperature. When you perform calculations using the equations given in this lesson, use absolute temperature and pressure, and remember that other factors can affect the behavior of the gas.

Answers to Self-Check Quiz

- 1-1. d. Perform work. Ref: 1.01
- 1-2. b. Resistance to movement. Ref: 1.07
- 1-3. b. Pounds per square inch, gauge. Ref: 1.13
- 1-4. c. Piston travel. Ref: 1.15, Fig. 1-3
- 1-5. d. Mechanical. Ref: 1.19
- 1-6. b. 1132 (psig). Ref: 1.25, Fig. 1-5
- 1-7. c. The pressure increases. Ref: 1.27
- 1-8. a. Pneumatic leverage. Ref: 1.33, Fig. 1-7
- 1-9. a. 2 in. Ref: 1.35, 1.36
- 1-10. d. Remains constant. Ref: 1.43, Fig. 1-9