

Basic Hydraulics

Table of Contents

Lesson One	Principles of Hydraulics.....	3
Lesson Two	Hydraulic Fluids.....	17
Lesson Three	Strainers and Filters.....	33
Lesson Four	Reservoirs and Accumulators.....	49
Lesson Five	Hydraulic Pumps.....	65
Lesson Six	Piping, Tubing, and Fittings.....	81
Lesson Seven	Directional Control Valves.....	97
Lesson Eight	Pressure Control Valves.....	113
Lesson Nine	Cylinders.....	129
Lesson Ten	Hydraulic Motors.....	145

© Copyright 1986, 1996, 1998, 1999, 2001 by TPC Training Systems, a division of Telemedia, Inc.

All rights reserved, including those of translation.

Printed and videotaped courseware are subject to the copyright laws of the United States. You are not authorized to make any copies of this material. If you do, then you are subject to the penalties provided under the copyright law, which include statutory damages up to \$50,000 for each infringement of copyrighted material, and also recovery of reasonable attorneys' fees. Further, you could be subject to criminal prosecution pursuant to 18 U.S.C. § 2319.

BASIC HYDRAULICS

Lesson One

***Principles of
Hydraulics***

PREVIEW
COPY



TPC Training Systems

30701

Lesson**1****Principles of Hydraulics****TOPICS**

Fluid Power and Hydraulics
 Force, Weight, and Mass
 Pressure
 Work, Power, and Energy
 Incompressibility and Nondiffusion
 Hydrostatic Pressure

Pascal's Law
 Transmission of Fluid Power
 Fluid Flow in Pipes
 Bernoulli's Principle
 The Effect of Heat on Liquids
 Hydraulic Power Systems

OBJECTIVES

After studying this Lesson, you should be able to...

- Explain the difference between atmospheric and gauge pressure.
- Demonstrate how power is calculated.
- Explain Pascal's Law.
- Describe the difference between laminar and turbulent flow.
- Name the main components of a hydraulic system.

KEY TECHNICAL TERMS

Force 1.04 a push or pull exerted on an object to change its position or direction of movement

Weight 1.05 a downward force that results from the gravitational pull on an object

Mass 1.06 the amount of matter in an object

Specific gravity 1.07 a measure of the density of a liquid

Pressure 1.08 the amount of force exerted on an object divided by the area over which the force is exerted

Work 1.11 the result of a body being moved through a distance by a force

Power 1.13 the amount of work done in a given amount of time

This Unit covers the general operating characteristics and principles of hydraulic systems and hydraulic system components. Included in this Unit are construction features of the different components and accessories used with hydraulic systems. Knowledge of how the equipment is constructed, and how it works, is extremely important to you as a maintenance craftsman.

This Lesson describes the basic operating principles of a hydraulic system, including fluid flow, power determination, hydraulic transfer, and pressure/movement characteristics. Understanding fluid flow and pressure will help you understand some of the problems that arise in a hydraulic system and enable you to take corrective steps.

Fluid Power and Hydraulics

1.01 Modern industrial equipment makes use of many *fluid power systems*. Fluid power systems perform work by transmitting force through a fluid. The fluid can be either a *liquid*, such as oil or water, or a *gas* such as compressed air, nitrogen, or carbon dioxide. A fluid power system that uses gas as the transmitting fluid is called a *pneumatic* system. A system that uses liquid as the transmitting fluid is called a *hydraulic* system. The word “hydraulic” is derived from the Greek words “hydro” (meaning water) and “aulis” (meaning pipe). Originally, the term hydraulic referred only to the flow of water in pipes. Today it is taken to mean the flow of any liquid in a system.

1.02 Some common examples of hydraulic systems include automobile braking and power steering systems, hydraulic elevators, and hydraulic lifts in gasoline stations. Hydraulic systems also are used on dump trucks, road graders, and earth-moving and excavating equipment.

1.03 There also are many uses for hydraulic systems in industrial plants. Hydraulic power is particularly suitable for operating jacks, lifts, hoists, presses, riveting machines, torque converters, tool-feeding mechanisms, and test equipment. As these examples show, hydraulic systems vary widely. However, they all operate using the same basic principles. Before proceeding with the components and operation of hydraulic systems, this Lesson will review some laws of force and motion, and explain how they are utilized in conjunction with hydraulic principles.

Force, Weight, and Mass

1.04 A *force* is a push or a pull that is exerted on an object. Force can cause an object to start moving, stop

moving, change speed, or change direction. In a hydraulic system, force must be present at all times in order for the system to function. As shown in Fig. 1-1, a pump exerts a force on a stream of hydraulic fluid. This force must be sufficient both to overcome the fluid’s resistance to flow and to do the work of the system. The more work the system must do, the more force is required. Force is measured in pounds (lb) in the English system, and in newtons (N) in the metric system.

1.05 An object has *weight* as a result of the gravitational pull exerted on it. Weight is always a downward force. In a hydraulic system, the fluid in the reservoir, in the lines, or in any of the components has weight. This is true whether the fluid is standing still or in motion.

1.06 All objects or substances also have *mass*. Mass is a measure of the amount of matter in an object and its resistance to change in motion. The mass of an object determines its weight on the earth,

Fig. 1-1. Force in a hydraulic system

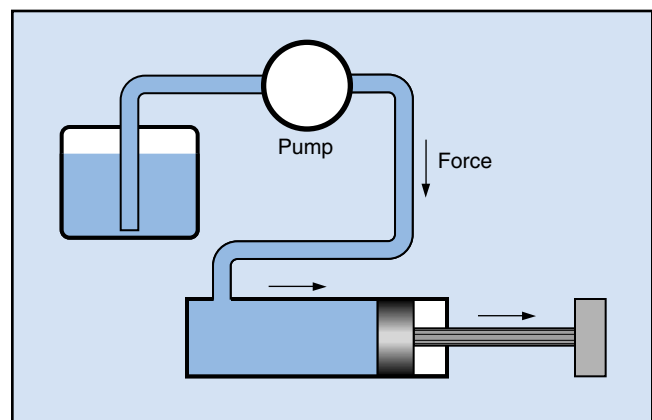
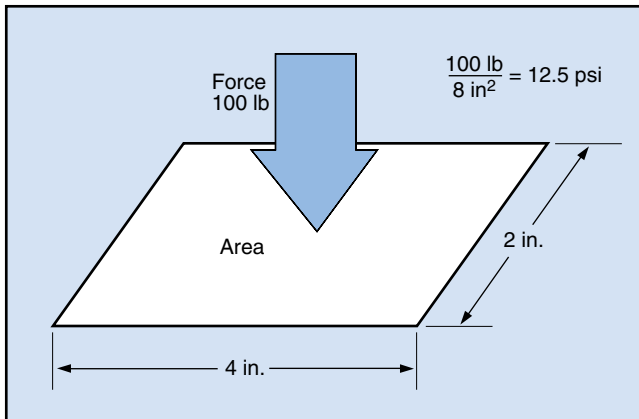

Fig. 1-2. Determining pressure



or in any other gravitational field. (On the earth's surface, a 1 lb mass weighs one pound on a spring scale. But on the moon's surface, because of the weaker pull of gravity, a 1 lb mass would weigh only about 2.5 oz) The mass of an object also determines how much force is required to cause a change in its motion. Mass is measured in pounds (lb) in the English system, and in kilograms (kg) in the metric system.

1.07 The density (mass per unit of volume) of a liquid is described in terms of *specific gravity*. The specific gravity of any liquid is its weight compared to the weight of an equal volume of water at the same temperature. The specific gravity of water is 1.0. Petroleum oil has a specific gravity of 0.78 at 120°F (49°C). Certain hydraulic fluids have a specific gravity of a fluid usually is not functionally important, it can be used to help determine the type of hydraulic fluid that is present in a system.

Pressure

1.08 *Pressure* is the amount of force exerted on an object or a substance divided by the area over which the force is exerted. Pressure is measured and specified in pounds per square inch (psi) in the English system, and in newtons per square meter (N/m²) in the metric system. As shown in Fig. 1-2, if a 100-lb force is applied to an area of 8 in², the resulting pressure is 12.5 psi. Force is calculated by multiplying the pressure times the area.

1.09 When working with hydraulic systems, you must be concerned with two kinds of pressure—*atmospheric* and *hydraulic*. *Atmospheric pressure* (at

14.7 psi) is at work at all times on fluid reservoirs that are vented to the atmosphere. *Hydraulic pressure* is created by the pump and acts on all internal passages on the discharge side. On the intake side a “negative” pressure exists. This is referred to as a *partial vacuum*, and is expressed in inches of mercury below atmospheric pressure.

1.10 The pressure gauges used in hydraulic systems measure only pressure that is higher than the atmospheric pressure that surrounds them. Therefore, an unconnected pressure gauge has a reading of 0 psig (zero pounds per square inch gauge). A reading of 100 on a hydraulic pressure gauge indicates a fluid pressure of 100 psig. To obtain total pressure, atmospheric pressure (14.7 psi) is added to the gauge pressure. The total pressure is 114.7 psia (pounds per square inch absolute). In hydraulics, the distinction between psig and psia is usually unimportant, so the term psi is commonly used in place of psig.

Work, Power, and Energy

1.11 *Work* takes place when a body or object is moved through a distance by a force. The amount of work accomplished is expressed in foot-pounds (ft-lb) or inch-pounds (in-lb) in the English system, and in newton-meters (N-m) in the metric system:

$$\text{force (lb)} \times \text{distance (ft)} = \text{work (ft-lb)}$$

1.12 In a hydraulic system, force is exerted by fluid pressure acting on the flow area. Work done by a hydraulic cylinder is calculated as follows. Hydraulic force is expressed in pounds:

$$\text{pressure (psi)} \times \text{piston area (in}^2\text{)} = \text{force (lb)}$$

Therefore, since force in pounds is multiplied by distance in inches, the answer is computed in inch-pounds, and must be divided by twelve to convert it to foot-pounds:

$$\begin{aligned} \text{force (lb)} \times \text{piston travel (in)} &= \\ \text{hydraulic work (in-lb)} \div 12 &= \text{ft-lb} \end{aligned}$$

A comparison between mechanical and hydraulic work is shown in Fig. 1-3.

1.13 *Power* is defined as the amount of work (ft-lb) done in a given amount of time (usually minutes,

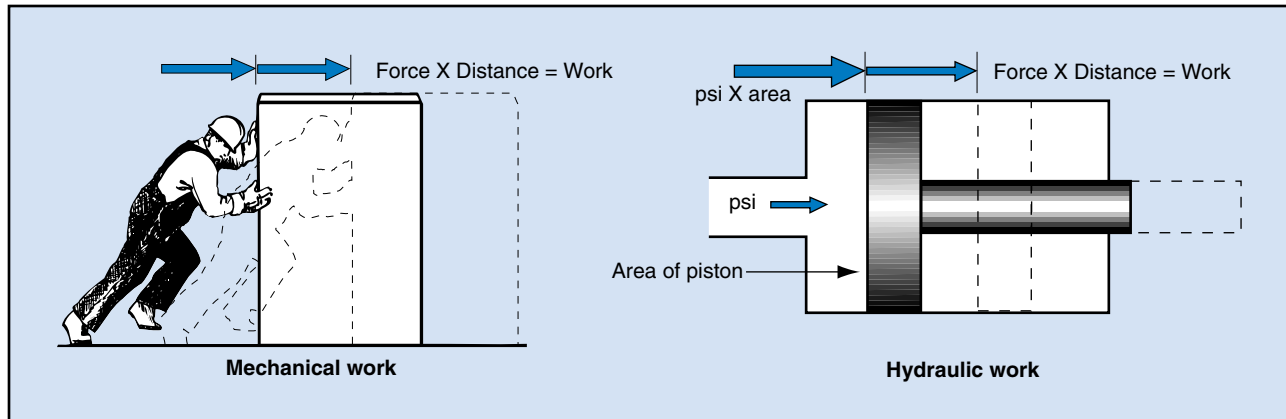
Fig. 1-3. Comparison between hydraulic and mechanical work

sometimes seconds). Thus, power is calculated in foot-pounds per minute (ft-lb/min):

$$\text{power (P)} = \text{work (ft-lb)} \div \text{time (min or s)} \\ = \text{ft-lb/min or ft-lb/s}$$

1.14 For the amount of power to be meaningful, it must be compared with some unit of measure. The common unit of measure for power is the *horsepower*, which is expressed as follows: one horsepower (1 hp) = 33,000 ft-lb/min or 550 ft-lb/s. In order to determine a pump's horsepower, you must calculate the horsepower required on the cylinder end. One kilowatt (1 kW) = 1.341 hp.

1.15 To do work or use power, energy must be expended. The Law of Conservation of Energy states that energy cannot be created or destroyed—it can only be transformed. Energy usually is measured in kilowatt hours (kWh).

1.16 As you know, not all energy is used to perform work. A certain amount of energy is expended, when doing work, to overcome friction. This energy is not lost, but changed into heat energy.

1.17 The types of energy used in hydraulic systems include the following:

- *electrical energy*—needed to operate the pump motor
- *hydraulic energy*—produced by the pump
- *kinetic energy*—produced when the hydraulic fluid moves a piston
- *potential energy*—produced when the piston has raised an object from one level to a higher level
- *heat energy*—produced by friction in the pump motor, pump, piston, and hydraulic fluid.

The Programmed Exercises on the next page will tell you how well you understand the material you have just read. Before starting the exercises, remove the Reveal Key from the back of your Book. Read the instructions printed on the Reveal Key. Follow these instructions as you work through the Programmed Exercises.

8 Programmed Exercises

1-1. The fluid in a fluid power system can be either a(n) _____ or a(n) _____.	1.1. LIQUID; GAS Ref: 1.01
1-2. A push or pull applied against an object to move it is called a(n) _____.	1-2. FORCE Ref: 1.04
1-3. Gravitational force gives an object _____.	1-3. WEIGHT Ref: 1.05
1-4. The density of a liquid is expressed in terms of _____.	1-4. SPECIFIC GRAVITY Ref: 1.07
1-5. The specific gravity of a liquid is determined by comparing the weight of the fluid to the weight of an equal volume of _____ at the same temperature.	1-5. WATER Ref: 1.07
1-6. The amount of work done when an object is moved through a distance by a force is expressed in units of _____.	1-6. FOOT-POUNDS Ref: 1.11
1-7. The amount of work done in a given period of time is called _____.	1-7. POWER Ref: 1.13
1-8. Name the four types of energy produced in a hydraulic system.	1-8. HYDRAULIC, KINETIC, POTENTIAL HEAT Ref: 1.17

Incompressibility and Nondiffusion

1.18 One of the problems encountered in a hydraulic system is that of storing the liquid. Unlike air, which is readily compressible and is capable of being stored in large quantities in relatively small containers, a liquid cannot be compressed. It is not possible to store a large amount of hydraulic fluid in a small tank because liquids, for all practical purposes, are *incompressible*.

1.19 *Diffusion* can be described as the rapid intermingling of molecules of one gas or liquid with another. This process should not be confused with evaporation, which is the changing of a liquid to a gas. Because of its slow evaporation rate at atmospheric pressure, hydraulic fluid can be placed in an open container or poured from one container into another without diffusing. This is *nondiffusion*. Gases, however, cannot be placed in open containers, because they would diffuse rapidly into the surrounding air. Therefore, gases are always stored in closed containers.

Hydrostatic Pressure

1.20 Figure 1-4 shows a number of differently shaped, connected, open containers. Note that the liquid level is the same in each container, regardless of the shape or size of the container. This occurs because pressure is developed, within a liquid, by the weight of the liquid above. If the liquid level in any one container were to be momentarily higher than that in any of the other containers, the higher pressure at the bottom of this container would cause some liquid to flow into the container having the lower liquid level. Also, the pressure of the liquid at any level (such as Line A) is the same in each of the containers. Pressure increases because of the weight of the liquid. The farther down from the surface, the more pressure is cre-

Fig. 1-5. Pascal's Law

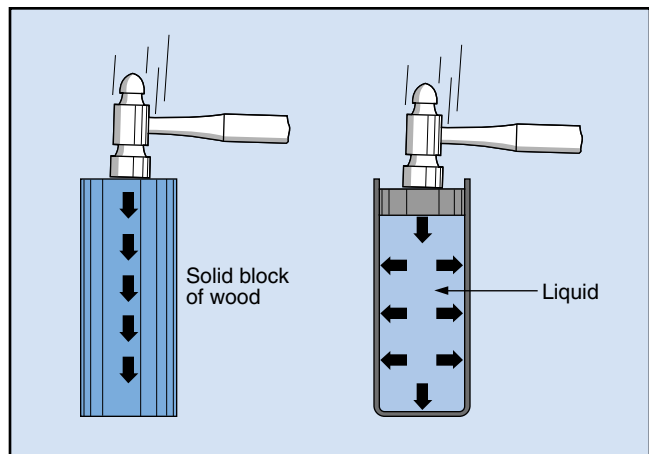

ated. This illustrates that the *weight*, not the volume, of liquid contained in a vessel determines the pressure at the bottom of the vessel.

Pascal's Law

1.21 The previous paragraphs explain what happens to liquid in open containers. Pascal's Law states that when pressure is exerted on a confined liquid, the pressure is transmitted equally in all directions through a liquid, as shown in Fig. 1-5. If the hammer strikes the solid block of wood, the force is transmitted in a straight line. But if the hammer strikes a liquid, force is transmitted in all directions. Similarly, the pressure exerted on the liquid in Fig. 1-6 on the following page is distributed equally by the liquid throughout the system. Note that the hydraulic pressure in the tubing and containers is the same in all directions.

Transmission of Fluid Power

1.22 Using a hydraulic fluid to accomplish work requires the application of all of the principles covered

Fig. 1-4. Hydrostatic pressure

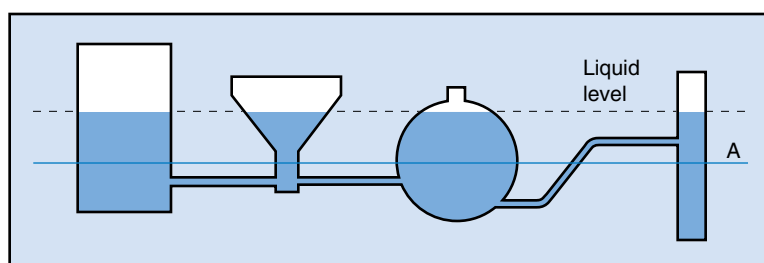
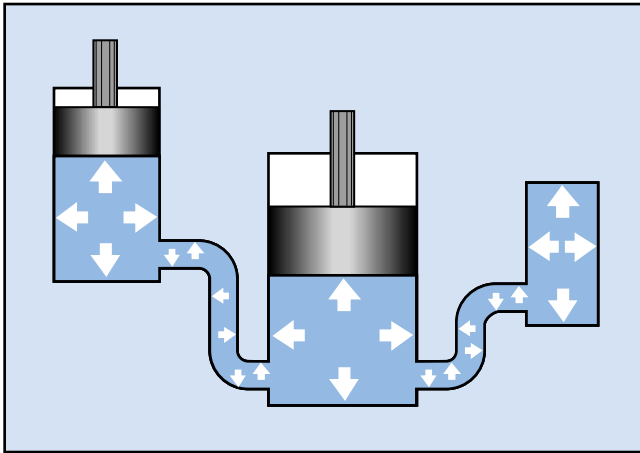

Fig. 1-6. Transmission of fluid pressure



so far. As shown in Fig. 1-7A, a force of 10 lb applied to piston 1 is transmitted through the liquid in the cylinder to piston 2. Pascal's Law states that pressure developed in a confined fluid is equal at every point. Therefore, the internal fluid pressure developed by piston 1 acts on piston 2. If the area of each piston is the same, the force developed on piston 2 is the same as the force applied by piston 1, discounting friction losses. This principle is the basis for all hydraulic power transmission systems.

1.23 The single cylinder in Fig. 1-7A has been replaced by two separate cylinders in Fig. 1-7B. Both are of the same diameter and are connected by a hydraulic line. The conditions present in Fig. 1-7B are not changed, because the hydraulic system has not been changed. The force applied to piston 1 is trans-

Fig. 1-7. Transmission of force

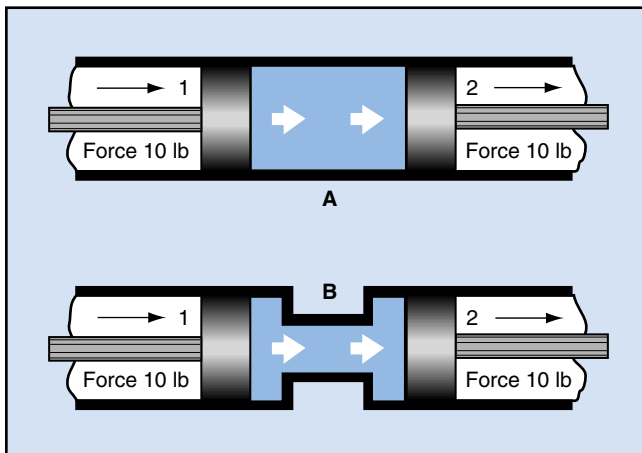

mitted through the fluid to piston 2. Although ignored here, remember that some frictional losses are present in any operating system.

1.24 A similar arrangement of two pistons connected by a tube is shown in Fig. 1-8. However, the pistons are placed in a vertical position and are of different sizes. If a force of 100 lb is applied to the 10-in² area of piston 1, a hydraulic pressure of 10 psi (100 lb ÷ 10 in²) is built up under piston 1, in the connecting tubing, and under the 50-in² area of piston 2. The 10 psi therefore exerts a total force of 500 lb (10 psi × 50 in²) on piston 2. This increase in power is called *hydraulic leverage*, and occurs in all similar applications.

1.25 If the applied force is reversed and the 500 lb in Fig. 1-8 is applied *against* piston 2, the output force on piston 1 is reduced to 100 lb. The calculations remain the same:

- $500 \text{ lb} \div 50 \text{ in}^2 = 10 \text{ psi}$
- $10 \text{ psi} \times 10 \text{ in}^2 = 100 \text{ lb}$

1.26 These examples demonstrate how force can be increased or decreased in a hydraulic system by leverage. There is another principle of leverage that you must remember. That is, for every increase in force in a two-piston system, there is a corresponding decrease in movement. If piston 1 in Fig. 1-8 moves 5 in, it displaces 50 cubic inches (in³) of fluid (5 in × 10 in² = 50 in³). The 50 in³ of hydraulic fluid are transmitted through the system to piston 2. The 50 in³ of

Fig. 1-8. Unequal piston areas

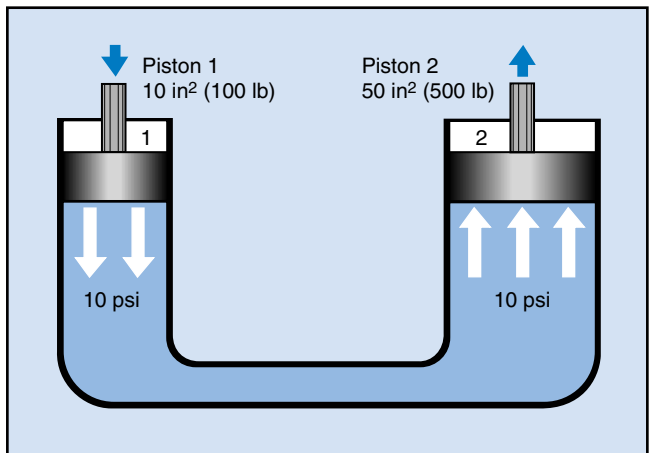

fluid fill the 50-in² area of piston 2, causing it to move one inch ($50 \text{ in}^3 \div 50 \text{ in}^2 = 1 \text{ in.}$).

1.27 The arrangement of pistons shown in Fig. 1-8 provides a ratio of 5 to 1 for any force applied on piston 1. At the same time the amount of movement of piston 2 is $\frac{1}{5}$ the movement of piston 1. The speed of piston 2 is also $\frac{1}{5}$ the speed of piston 1. No matter what the ratio, if you want to multiply the hydraulic force of the system, you will reduce the amount and speed of movement. On the other hand, if the force is applied to the larger piston, you increase the amount and speed of movement, but you reduce the force exerted by the system.

Fluid Flow in Pipes

1.28 Streamline, or *laminar*, flow is the ideal type of fluid flow in a hydraulic power system because all of the particles of a fluid move in parallel lines, as shown in Fig. 1-9A. During the flow, the layer of fluid next to the surface of the pipe moves the slowest because of friction between the fluid and pipe. Each inner layer of fluid slides along on the next layer of fluid with less and less friction until the fluid layer near the center of the flow passage move the fastest. Figure 1-9B shows that the velocity of flow near the center of the pipe is greatest.

1.29 *Turbulent* flow conditions usually occur because the fluid passage is too small for the required flow velocity or because the viscosity of the hydraulic fluid is low. Also, rough or irregularly formed fluid passages, sudden enlargements or reductions in the diameter of the fluid passages, and sudden changes in the direction of flow (as pictured in Fig. 1-10) all contribute to turbulence and should be avoided.

1.30 Turbulent flow heats up the hydraulic fluid more than laminar flow does, wastes power by requiring more fluid pressure, and tends to wear out hydraulic equipment more rapidly. In addition, turbulent flow can release the air that is suspended in the hydraulic oil, thus forming large air bubbles or pockets in the lines and components. This is called *cavitation*. Cavitation is undesirable because air bubbles make the hydraulic system sluggish and less responsive. Large air pockets in a hydraulic system also cause wear and can render the system completely inoperative.

Fig. 1-9. Streamline flow

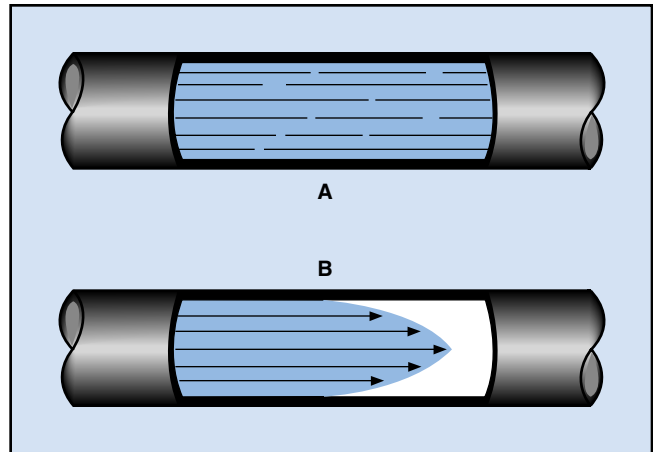

Fig. 1-10. Turbulent flow

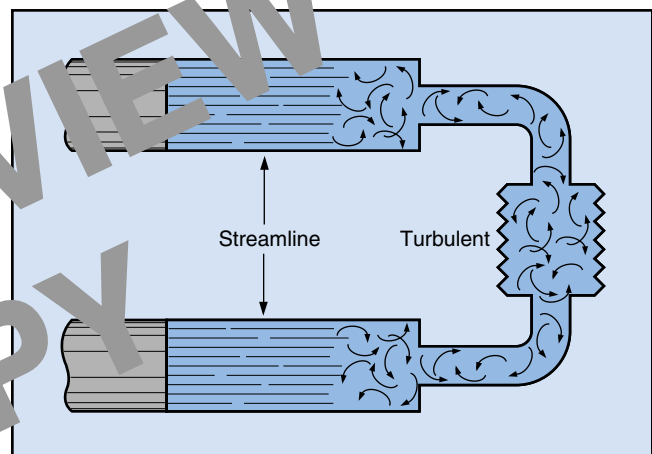
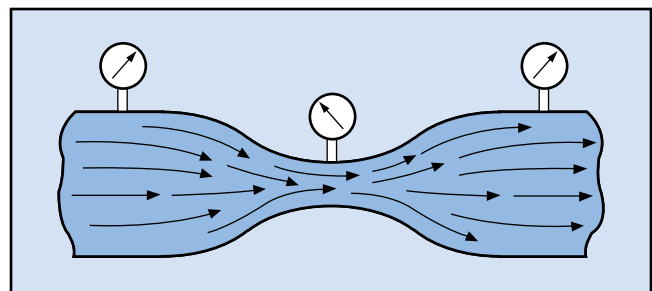
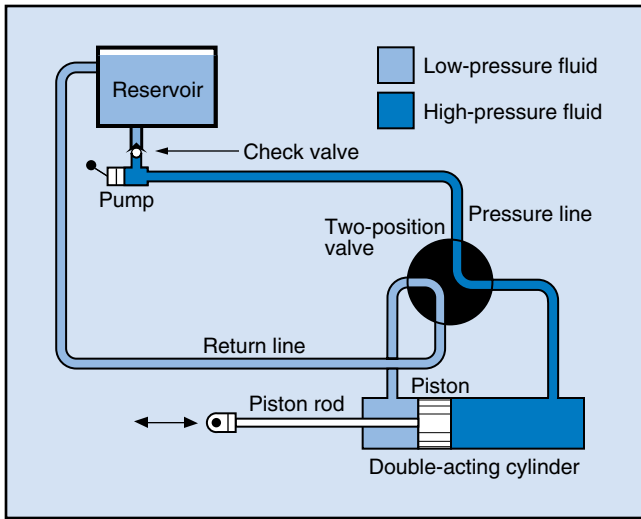

Fig. 1-11. A gradual piping constriction



1.31 When fluid must pass through a passage of reduced size, the restriction should be as gradual as possible, as shown in Fig. 1-11. As the fluid passes through the constriction, the flow increases in velocity.

Fig. 1-12. A basic hydraulic system



Bernoulli's Principle

1.32 Hydraulic fluid in a system possesses two types of energy—kinetic and potential. Kinetic energy is present when the fluid is in motion. The faster the fluid moves, the more kinetic energy is used. Potential energy is a result of the fluid pressure. The total energy of the fluid is the sum of the kinetic and potential energy. Bernoulli's principle states that the total energy of the fluid always remains constant. Therefore, when the fluid flow in a system increases, the pressure must decrease. You may note that when fluid starts to flow through a hydraulic system, the pressure

drops slightly. When the flow stops, the pressure rises again. The pressure gauges shown in Fig. 1-11 indicate this balance more clearly.

The Effect of Heat on Liquids

1.33 As you know, liquids expand when they are heated. Hydraulic oil is no different. When placed in a completely closed vessel and heated, it will exert great pressure on the vessel. Because liquids cannot be compressed, a very small rise in temperature (and expansion) can exert enormous pressure on cylinders, accumulators, and closed reservoirs. These internal pressures can also cause much internal system damage.

1.34 Heat also causes hydraulic oil to thin out. Sometimes the oil may thin out enough to reduce the maximum pressure which the pump in a system can develop. In many cases, heat causes seals and packings to leak because of the lowered oil viscosity. Heat also causes the oil to deteriorate. Unnecessary heating of the oil in a hydraulic system must be avoided. If it cannot be avoided, cooling should be provided.

Hydraulic Power Systems

1.35 Now that you have studied some preliminary information, take a look at a typical hydraulic power system. A hydraulic power system is a closed piping circuit in which a liquid under controlled pressure is used to do work. The basic hydraulic system shown in Fig. 1-12 is composed of the following elements:

Fig. 1-13. A basic hydraulic system with accessories

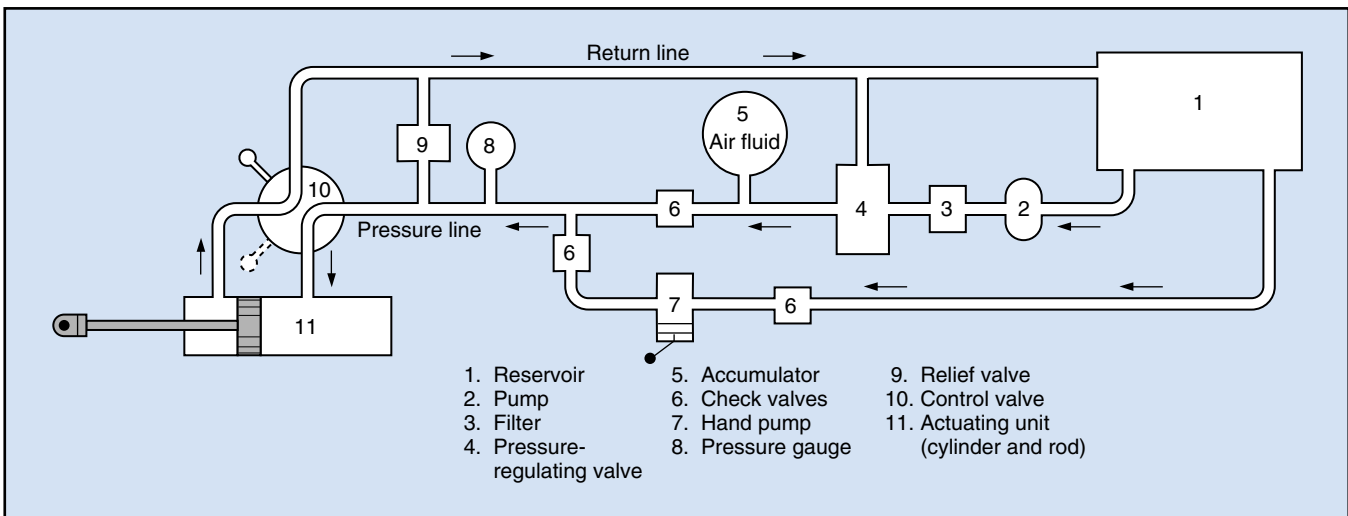

- a *reservoir* to store the hydraulic fluid
- a *pump* to provide fluid pressure to the system
- a *control valve* to direct the flow of fluid
- an *actuating unit*, such as a cylinder
- a suitable *hydraulic fluid*
- *pipng* or *tubing* to circulate the fluid through the system.
- an *accumulator*, which acts as a cushion and prevents large variations in fluid pressure from occurring in the system
- *check valves*, which permit fluid flow only in the desired directions
- a *hand pump* for operating the system manually if necessary
- a *pressure gauge*, which indicates the amount of fluid pressure in the system

1.36 The basic hydraulic power system often if made more complex by the addition of several other components, as shown in Fig. 1-13. These additional components enable the system to accomplish a greater range of work, and they permit the system to function with greater reliability. The following components make up an actual hydraulic power system:

- a *reservoir* to store the hydraulic fluid
- a *pump* to provide fluid pressure to the system
- a *filter* to remove dust, chips, and other foreign particles from the fluid
- a *pressure-regulating valve*, which keeps the fluid pressure in the main part of the system at the proper level
- a *relief valve*, which prevents the system pressure from rising too high if the pressure-regulating valve fails
- *pipng* or *tubing* to circulate the fluid through the system
- a *control valve* to change the flow of fluid from one end of the actuator to the other, and to reverse the motion of the piston
- an *actuating unit*, such as a cylinder, which does some kind of useful work when acted upon by hydraulic fluid under pressure
- a suitable *hydraulic fluid*.

Most of these components are discussed in detail in the following Lessons of this Unit.

14 Programmed Exercises

<p>1-9. The rapid intermingling of molecules of one gas or liquid with another is called _____.</p>	<p>1-9. DIFFUSION Ref: 1.19</p>
<p>1-10. Pascal's Law states that when pressure is exerted on a confined liquid, the pressure is transmitted _____ in all directions throughout the liquid.</p>	<p>1-10. EQUALLY Ref: 1.21</p>
<p>1-11. Force can be increased or decreased in a hydraulic system by means of hydraulic _____.</p>	<p>1-11. LEVERAGE Ref: 1.24-1.26</p>
<p>1-12. If two pistons have a force ratio of 4 to 1, the amount of movement of piston 2 is _____ the movement of piston 1.</p>	<p>1-12. $\frac{1}{4}$ Ref: 1.27</p>
<p>1-13. The ideal fluid flow in a hydraulic power system is called _____ flow.</p>	<p>1-13. LAMINAR Ref: 1.28</p>
<p>1-14. Turbulent flow wastes power by generating excess _____ in the fluid.</p>	<p>1-14. HEAT Ref: 1.30</p>
<p>1-15. In a hydraulic power system, fluid flow is directed by a(n) _____.</p>	<p>1-15. CONTROL VALVE Ref: 1.35</p>
<p>1-16. The component used to maintain system pressure in a hydraulic system is the _____.</p>	<p>1-16. PRESSURE-REGULATING VALVE Ref: 1.36</p>

Answer the following questions by marking an "X" in the box next to the best answer.

- 1-1. Force is measured in units of _____ in the metric system.
- a. kilograms
 - b. pounds
 - c. newton-meters
 - d. newtons
- 1-2. The mass of an object is
- a. the same as its weight
 - b. always a downward force
 - c. a measure of the amount of matter in it
 - d. the result of the gravitational pull exerted on it
- 1-3. The density of a fluid is expressed in terms of
- a. specific gravity
 - b. weight
 - c. psi
 - d. viscosity
- 1-4. The number of pounds of force applied to an area is measured in
- a. psia
 - b. psig
 - c. psi
 - d. inches of mercury
- 1-5. When calculating the work done by a hydraulic cylinder, you must know the hydraulic pressure and the piston's
- a. rod diameter
 - b. area and stroke
 - c. stroke and speed
 - d. diameter and speed
- 1-6. The theory that states that pressure in a confined liquid is distributed equally throughout the fluid is
- a. Bernoulli's Principle
 - b. Newton's Law
 - c. Pascal's Law
 - d. Turing's Theorem
- 1-7. If the force ratio between two different hydraulic pistons is a reducing ratio, the piston velocity
- a. increases
 - b. decreases
 - c. remains unchanged
 - d. is squared
- 1-8. Fluid flow in a hydraulic piping system should be
- a. laminar
 - b. restricted
 - c. turbulent
 - d. fast
- 1-9. Which of the following does not cause turbulent flow in hydraulic systems?
- a. High fluid velocity
 - b. Irregular passages
 - c. Rough pipes
 - d. Large-diameter pipes
- 1-10. Bernoulli's Principle states that the total energy of a hydraulic fluid is
- a. kinetic minus potential energy
 - b. always constant
 - c. the square of the kinetic energy
 - d. the square of the potential energy

SUMMARY

Most industrial plants have various types of hydraulic systems. In order to keep the systems in your plant operating properly and efficiently, you must understand the basics of hydraulics—the laws of force and motion—and be familiar with the basic hydraulic system components and their operation.

The basic hydraulic system includes a reservoir to hold the fluid, a pump to provide pressure to the system, and an actuating unit, usually a cylinder. The system also includes the hydraulic fluid and the piping or tubing used to circulate the fluid through the system. Most hydraulic systems also include a variety of valves and gauges.

Force, weight, and pressure work together in a hydraulic system to do the work. The amount of work produced in the system depends on the force exerted, how long it is exerted, and the distance the force moves the piston.

The system operates more efficiently when the fluid flow is laminar, or smooth, instead of turbulent. Turbulent flow wastes power and causes rapid wear of hydraulic components. Heat is another problem in hydraulic systems. The oil in the system should be kept cool for best performance. Heat can cause the hydraulic fluid to break down, and components to wear.

Answers to Self-Check Quiz

- 1-1. d. Newtons. Ref: 1.04
- 1-2. c. A measure of the amount of matter in it. Ref: 1.06
- 1-3. a. Specific gravity. Ref: 1.07
- 1-4. c. Psi. Ref: 1.08
- 1-5. b. Area and stroke. Ref: 1.12
- 1-6. c. Pascal's Law. Ref: 1.21, 1.22
- 1-7. a. Increases. Ref: 1.27
- 1-8. a. Laminar. Ref: 1.28
- 1-9. d. Large-diameter pipes. Ref: 1.29
- 1-10. b. Always constant. Ref: 1.32